

TYPICAL DETAIL : MOTORISED 220/30/45 RETRACT WITHIN LOUVRETEC STRUCTURAL FRAME

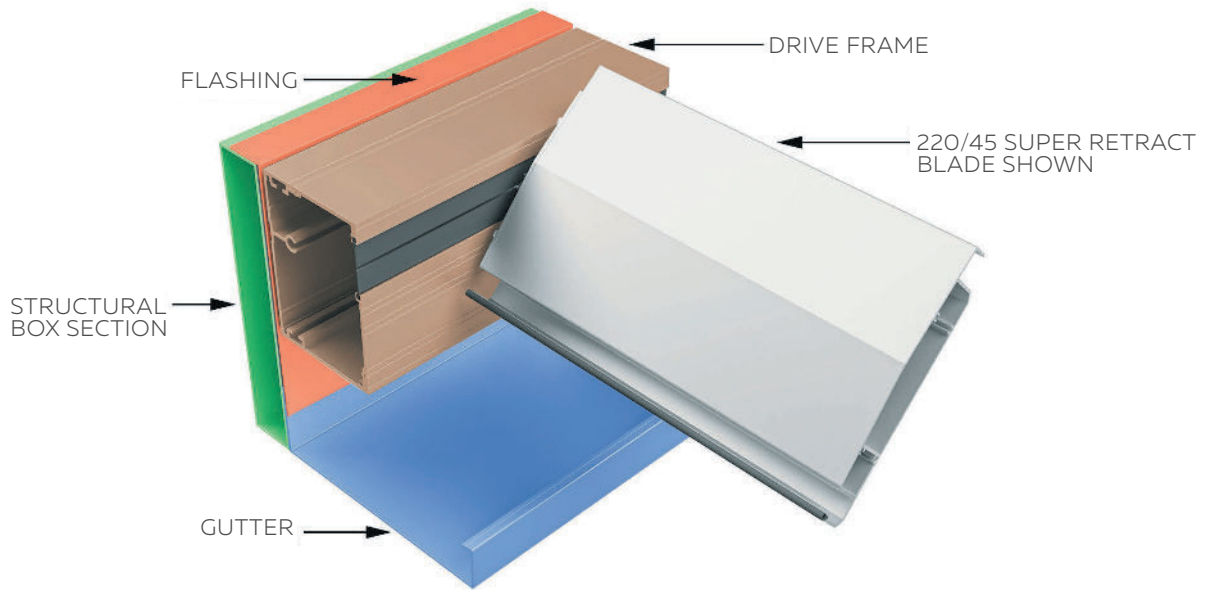

CROSS SECTION SHOWING DRIVE FRAME, BLADE, GUTTER & FLASHING WITHIN 300X50 BOX SECTION FRAME

TYPICAL DETAIL : FALL & CLEARANCES ON RETRACT BLADES

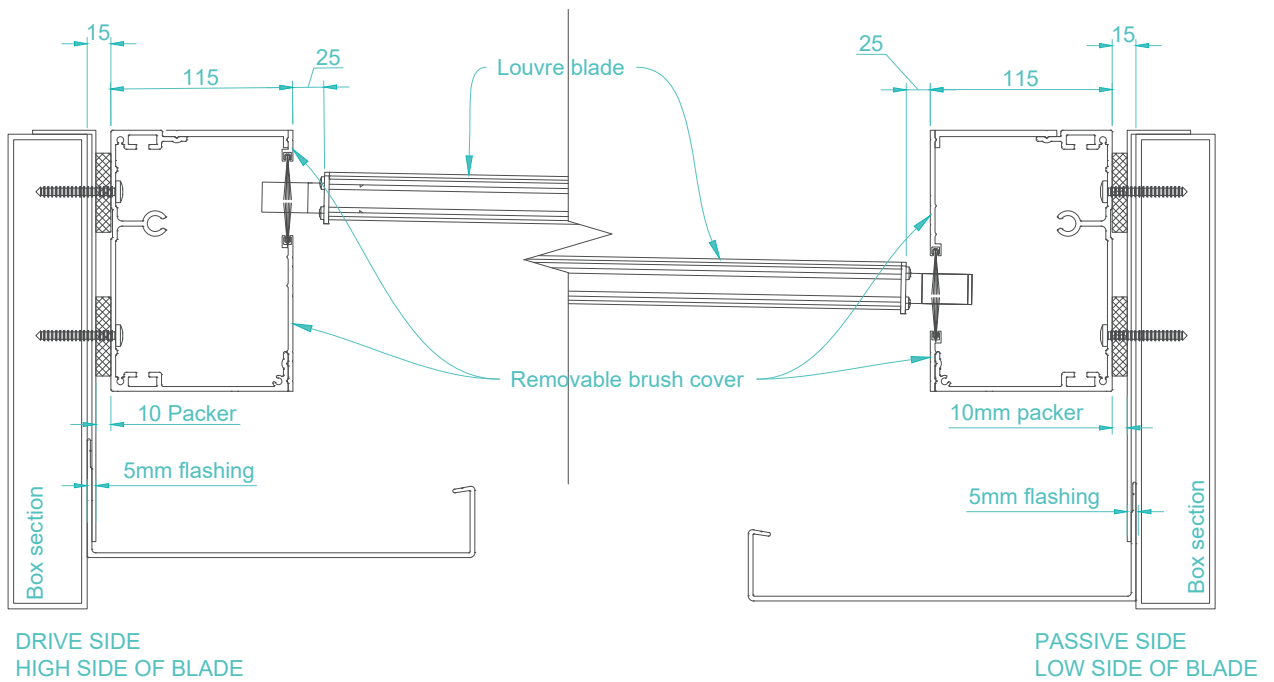

RETRACT ROOFS ARE TYPICALLY INSTALLED LEVEL

FALL ACROSS THE BLADES IS ACHIEVED WITH THE BLADES SET HIGHER ON THE DRIVE SIDE, FALLING 60mm TO THE PASSIVE SIDE.

60mm FALL IS COMMON ON ALL RETRACTS IRRESPECTIVE OF BLADE LENGTH.