

OPENING ROOFS 220/35 SLIMLINE PIVOT ROOF BLADE SPECIFICATIONS

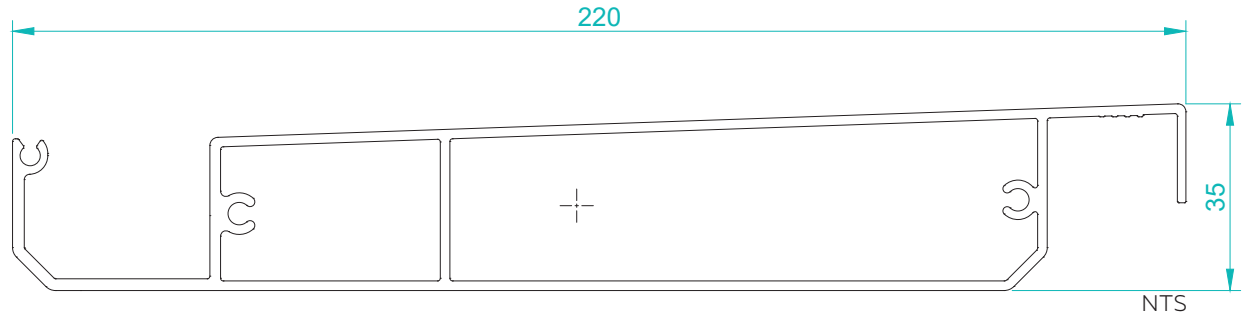

BLADE SPECIFICATIONS 220/35 SLIMLINE PIVOT ROOF



BLADE SPECIFICATIONS			
Blade cover - opening system	205 mm	Weight per linear metre - opening system	2.655 kg/lm
Weight per square metre - opening system	12.9 kg/sqm	Actual blade width	220 mm
Blade centres - opening system	205 mm		

SPANS AT A GLANCE NB:

Refer Engineering Section. Climate, terrain, shielding, location, type of structure contribute to determine spans.

WIND ZONE	INSIDE	LOW	MEDIUM	HIGH	VERY HIGH	EXTRA HIGH
Factored wind speed at building	Self wt	32 m/s 115 km/hr	37m/s 133 km/hr	44 m/s 158 km/hr	50 m/s 179 km/hr	55 m/s 198 km/hr
Ultimate limit state loads (kPa)		+1.1 & -1.38	+1.48 & -1.85	+2.09 & -2.61	+2.70 & -3.38	+3.27 & -4.08
220/35 SLIMLINE PIVOT ROOF	5600	4500	4000	3400	3000	2800

INSTALLATION OPTIONS



CALCULATE OPTIMUM FRAME
OPENING SIZES FOR SPIRAL PIVOT

Span: Check engineering span limits

Pivot: Calculation example showing 17 blades

STEP 1

16 blades x 205 Crs	3280
1 blade at 220 (blade size)	+ 220
17 blades	=3500

STEP 2

Blade cover	3500
+2/22mm clearance @ ends	=44
Total exact pivot length	=3544
Extra width 185mm gutter provides cover if clearance increases over 22mm at ends.	
Blade direction either Right Hand up or Left Hand up.	

CHOOSE DIRECTION OF BLADE PIVOT

